

ROLLER 110 - 130 NASTROSAC

Machines for garbage bags

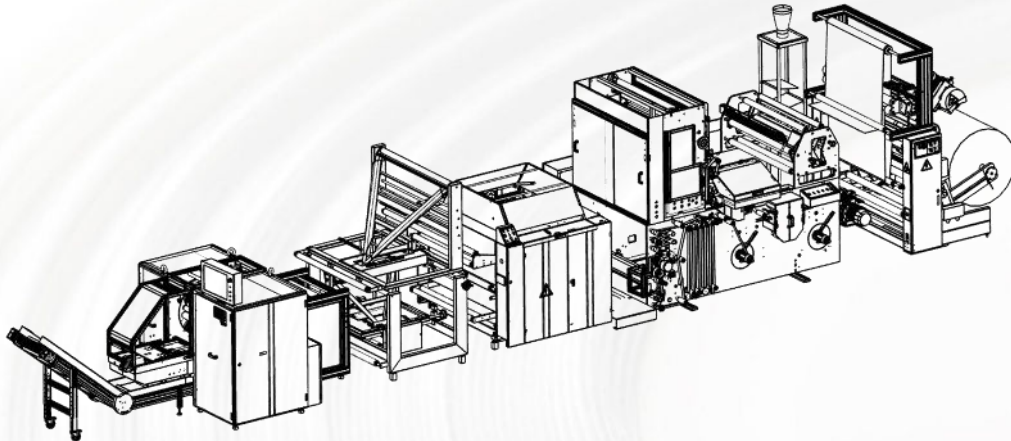

The Nastosac series welding machines enable the production of bottom welded and draw-tape bags, available in both overlapped (interleave) and continuous band formats with a ribbed texture to facilitate tearing, presented in rolls with adhesive paper strips.

| BOTTOM WELDED BAGS | BOTTOM WELDED INTERLEAVE BAGS |
|---|--|
|  |  |
| DRAW-TAPE BAGS | DRAW-TAPE INTERLEAVE BAGS |
|  |  |

TECHNICAL CHARACTERISTICS

| Machine model | | 110 | 110 Interleave | 130 |
|---------------------------------|----------------------------|-----------------------|-----------------------|-----------------------|
| Useful welding width | | 1100 mm | 1100 mm | 1300 mm |
| Minimum bag lenght | Bottom welded Draw tape | 250 mm 620 mm | 250 mm 620 mm | 250 mm 620 mm |
| Maximum bag lenght | Bottom welded Draw tape | 1500 mm 1050 mm | 1500 mm 1050 mm | 1500 mm 1050 mm |
| Minimum bag width | Bottom welded Draw tape | 620 mm 420 mm | 400 mm 400 mm | 620 mm 400 mm |
| Maximum bag width | Bottom welded Draw tape | 1100 mm 900 mm | 900 mm 900 mm | 130 mm 900 mm |
| Minimum thickness | | 0.010 mm | 0.010 mm | 0.010 mm |
| Maximum thickness | | 0.050 mm | 0.050 mm | 0.050 mm |
| Maximum mechanical speed | | 270 cycles/min | 270 cycles/min | 200 cycles/min |
| Maximum film speed | | 40 m/min 120 m/min | 40 m/min 120 m/min | 40 m/min 120 m/min |
| Materials | | HDPE, LDPE, LLDPE | | |

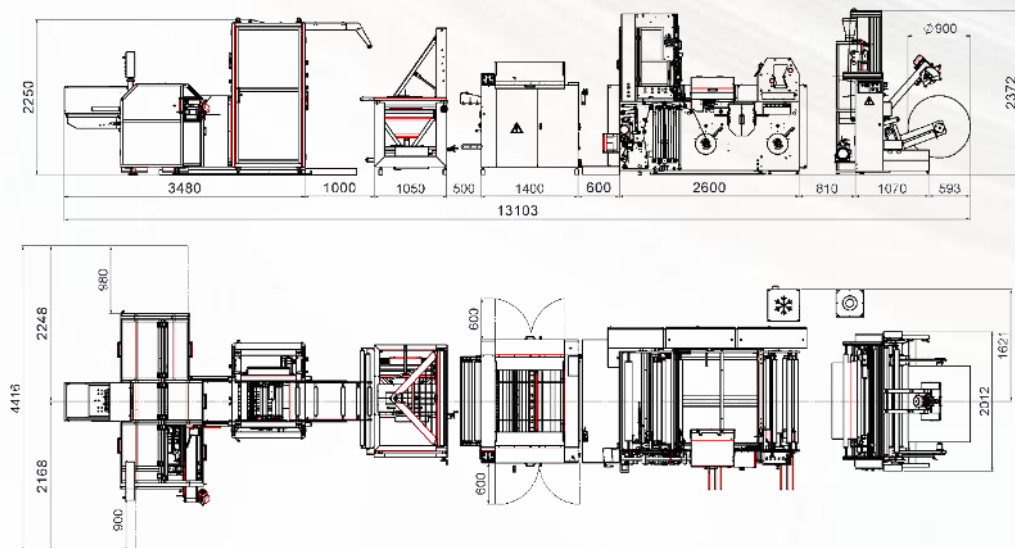
MACHINE LAYOUT

In.Pack Machinery Srl reserves the right to modify the content of this flyer at its sole discretion and without prior notice. All rights reserved.