

ROLLER 110 - 130 6M

Machines for garbage bags

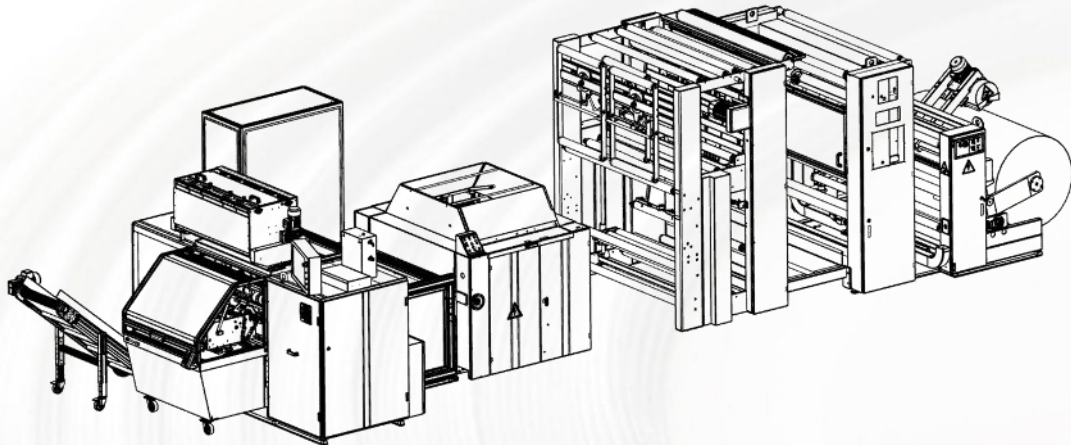

With the Roller series sealing lines it is possible to produce bottom welded bags in a continuous band perforated across to tear-off (bags on roll), working with 2 or 3 tracks and packaged in rolls with gummed paper bands.

GUSSETED BOTTOM WELDED BAG



C" FOLDED BOTTOM WELDED BAGS

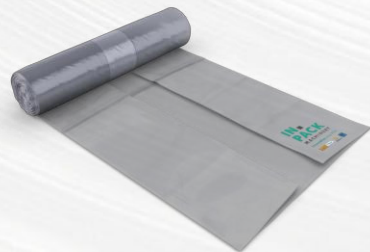

BOTTOM WELDED BAGS WITH STAR SEAL

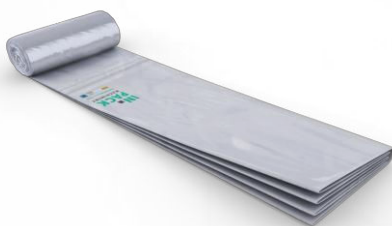

OPEN BOTTOM WELDED BAGS NOT GUSSETED



TECHNICAL CHARACTERISTICS

Machine model	110	130
Useful welding width	1100 mm	1300 mm
Minimum bag width	150 mm	150 mm
Minimum bag length	250 mm	250 mm
Maximum bag length	1500 mm	1500 mm
Minimum thickness	0.010 mm	0.010 mm
Maximum thickness	0.050 mm	0.050 mm
Maximum mechanical speed	250 cycles/min	250 cycles/min
Minimum - maximum film speed	40 m/min 150 m/min	40 m/min 150 m/min
Maximum roll diameter	110 mm	110 mm
Maximum roll width 2 tracks	425 mm	520 mm
Maximum roll width 3 tracks	300 mm	350mm
Type of materials	HDPE, LDPE, BIO	

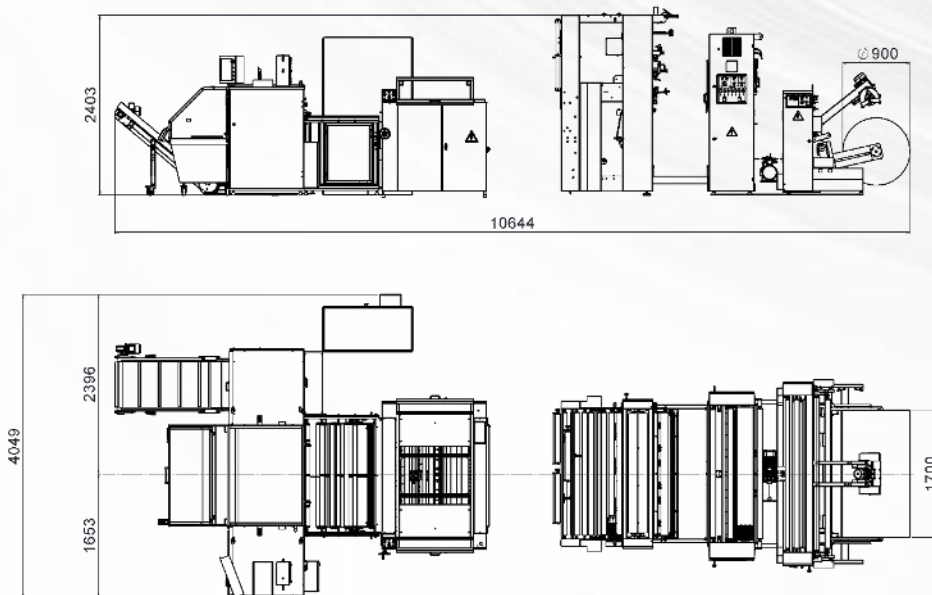
MACHINE LAYOUT

In.Pack Machinery Srl reserves the right to modify the content of this flyer at its sole discretion and without prior notice. All rights reserved.