

ROLLER 110 - 130 SHP 6M

Machines for fruit and vegetables bag

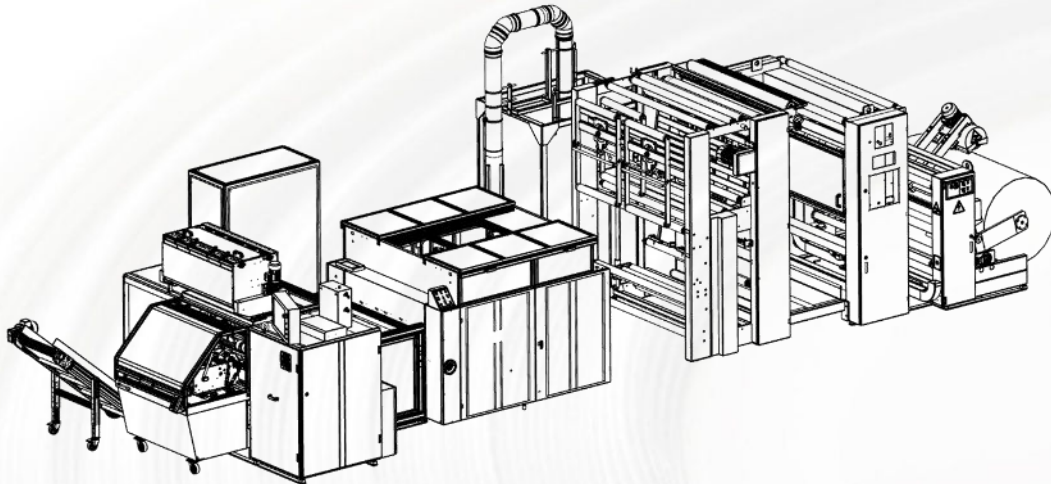

The Roller SHP series sealing lines produce bottom-welded and T-shirt bags with a perforated design for easy tear-off. It operates with 2 independent tracks or 3-4 standard tracks, and finished products are rolled and secured with gummed paper bands, optionally including a cardboard core.

<p>GUSSETED BOTTOM WELDED BAG</p>	<p>C" FOLDED BOTTOM WELDED BAGS</p>	<p>BOTTOM WELDED BAGS NOT GUSSETED</p>
		
<p>BOTTOM WELDED BAGS WITH STAR SEAL</p>	<p>T-SHIRT BAG</p>	<p>"C" FOLDED T-SHIRT BAGS</p>
		

TECHNICAL CHARACTERISTICS

Machine model	110	130
Useful welding width	1100 mm	1300 mm
Number of tracks	2 independent - 3 standard (optional cardboard core)	2 independent – 3 or 4 standard (optional cardboard core)
Minimum bag width	150 mm	150 mm
Maximum bag width	465 mm	600 mm
Minimum bag length	250 mm	250 mm
Maximum bag length	1500 mm	1500 mm
Minimum thickness	0.010 mm	0.010 mm
Maximum thickness	0.050 mm	0.050 mm
Maximum mechanical speed	250 cycles/min w/o puncher 230 cycles/min w/ puncher	250 cycles/min w/o puncher 230 cycles/min w/ puncher
Maximum – minimum film speed	40 m/min 150 m/min	40 m/min 150 mt/min
Maximum roll diameter	110 mm	110 mm
Minimum roll width	150 mm	150 mm
Maximum roll width	2 tracks 425 mm	2 tracks 520 mm
Type of materials	HDPE, LDPE, BIO	

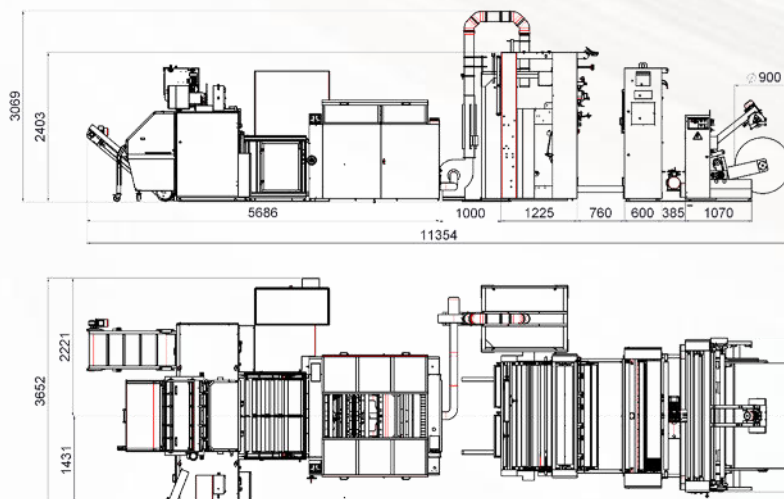
MACHINE LAYOUT

In.Pack Machinery Srl reserves the right to modify the content of this flyer at its sole discretion and without prior notice. All rights reserved.