

WRAPP 110 - 130

Machines for bottom welded bags and block – notes bags

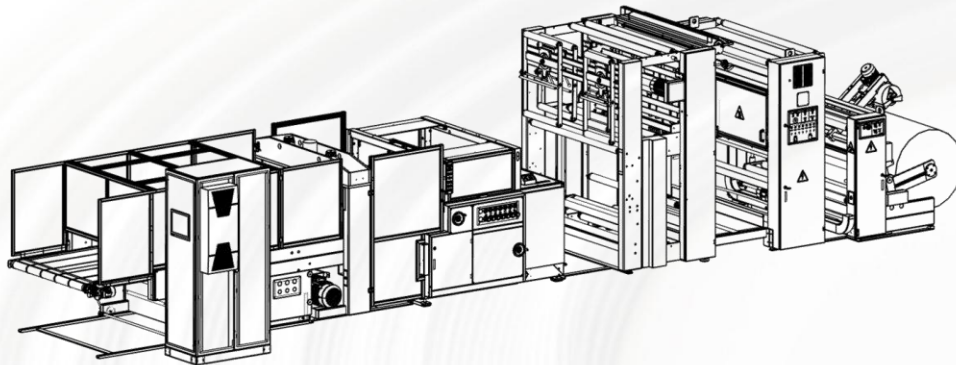

The Wrapp series welding lines enable the production of Bottom welded bags using a pin collection system. The standard lines can be customized further to manufacture additional bag formats, such as block – notes bags.

<p>BOTTOM WELDED BAG - GUSSETED</p>	<p>BOTTOM WELDED BAG - GUSSETED WITH PUNCHING UNIT</p>
	
<p>BLOCK NOTES BAG</p>	<p>BLOCK NOTES BAG WITH PUNCHING UNIT</p>
	

TECHNICAL CHARACTERISTICS

Machine model	110	130
Useful welding width	1100 mm	1300 mm
Maximum number of tracks	5	6
Minimum bag length	200 mm	200 mm
Maximum bag length	1300 mm	1300 mm
Minimum thickness	0.010 mm	0.010 mm
Maximum thickness	0.060 mm	0.060 mm
Maximum mechanical speed	300 cycles/min	280 cycles/min
Maximum film speed	150 mt/min	150 mt/min
Type of materials	HDPE, LDPE, BIO	

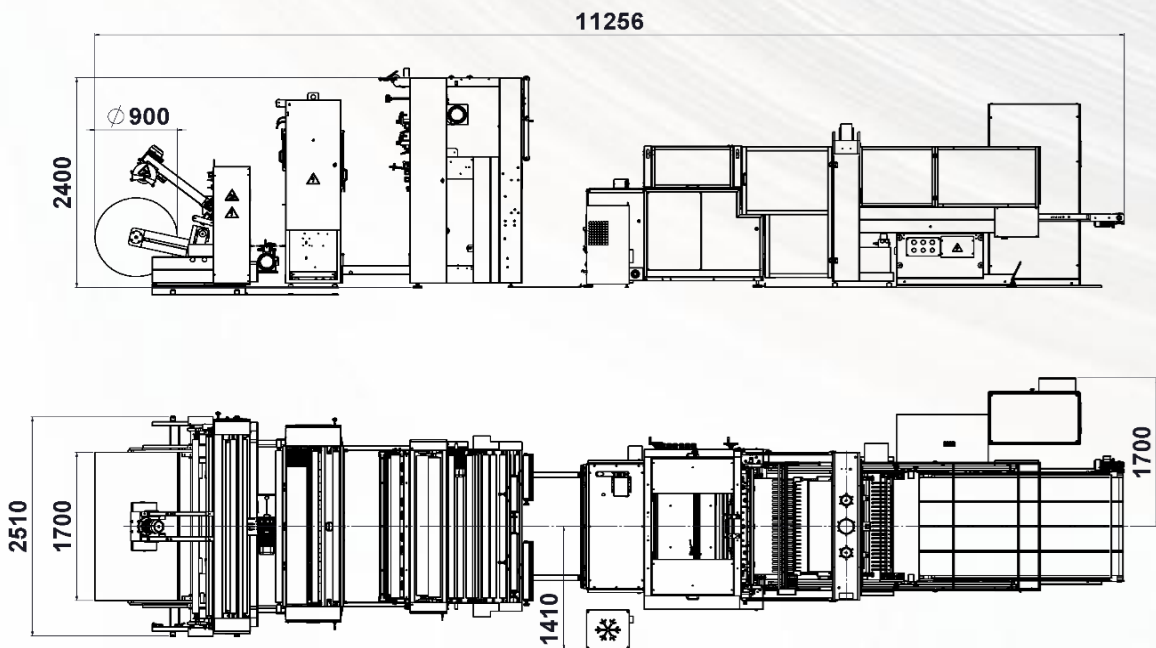
MACHINE LAYOUT

In.Pack Machinery Srl reserves the right to modify the content of this flyer at its sole discretion and without prior notice. All rights reserved.